



PERSONAL SCALE: FR-MS

(MS3200 Indicator, Product Type MS-3200)

FEATURES

1. Compact Dimensions: 220×90×40
2. **Material:** Aluminium
3. **Display Options:** LCD-display med 5 tecken
4. **Capacity/Division:**





TABELL 1

CAPACITY	DIVISION1	DIVISION 2	DIVISION 3
200 kg	0,05 kg	0,1 kg	0,2 kg

5. **Power:** Rechargeable battery 6×AA / AC adapter 9V 500mA
6. **Power saving:** auto shut-off timing selectable (120seconds/180seconds/240seconds/360seconds/Off)
7. **Operating Temperature:** 5 - 35°C
8. **Operating Humidity:** 25 % - 95 % RH
9. **4Keys:**
 - HOLD/BMI**, UNIT/WEIGHT , ZERO , TARE
 - HOLD/BMI** Press this key to store weight value
 - UNIT/WEIGHT** Toggle among KG and LB unit
 - ZERO** Zero the weight
 - TARE** Tare the weight
11. **Zero Range:** (4 % to full capacity)
12. **Tare Range:** (100 % to full capacity)
13. **Error Message indication:**
 - EEEEEE** Overload
 - ErrL** Power on zero count too low
 - ErrH** Power on zero count too high
 - ErrE** Eeprom Error
 - +** Low battery indication

- 14. Two calibration weight units : kg / lb
- 15. Open calibration weight
- 16. Power on zero-setting range: + 10%
- 17. Zero range: + 4% of full capacity
- 18. Three modes : Normal mode / Setting mode / Internal Auto Calibration mode
- 19. RS232 function

AUTO SHUT OFF MODE

STATE	DESCRIPTION	TIME FOR SHUT OFF	NOTE
	Low battery indication	30 seconds	
	EEPROM ERROR	30 seconds	
EEEE	Overload	30 seconds	
ErrH	Zero value higher	30 seconds	
	Zero value lower	30 seconds	
	Zero Tracking	According to time of shut off	
Negativ vikt	Display of weighing in minus value	According to time of shut off	
Samma viktvärde	Display of weighing in same value	According to time of shut off	Inclusion zero tracking and minus weight
Olika viktvärden	Display of weighing in diff. value	No Off	Inclusion minus weight

BESKRIVNING AV TANGENTERN

HOLD BMI	UNIT	WEIGHT	ZERO	TARE
----------	------	--------	------	------

1. HOLD/BMI:

- A. Press this key to store weight value.
- B. To release Hold feature, Press the HOLD key again.
- C. To release Hold feature and tare the weight, Press the TARE key.
- D. Press and hold this key, the scale will enter to BMI setting.

2. UNIT/WEIGHT:

- A. Välj viktenhet: kg eller lb.
- B. Sist använda viktenhet visas nästa gång enheten startas.

3. ZERO:

- A. When there's load on the scale , press this key to return to zero
- B. Put a container on the scale, press this key to tare the weight, and the tarred value is stored..

4. TARE:

- A. When there's load on the scale , press this key to return to zero.
- B. Put a container on the scale, press this key to tare the weight, and the tarred value is stored.

5. STRÖMBRYTARE:

When the scale is in use or not in use, please turn the power on or the power off.

FUNCTION TABLE:

Press and hold [**HOLD/BMI**] to turn the power, and then press continuously [**UNIT/WEIGHT**] three times, the display will show the “**SET**”.

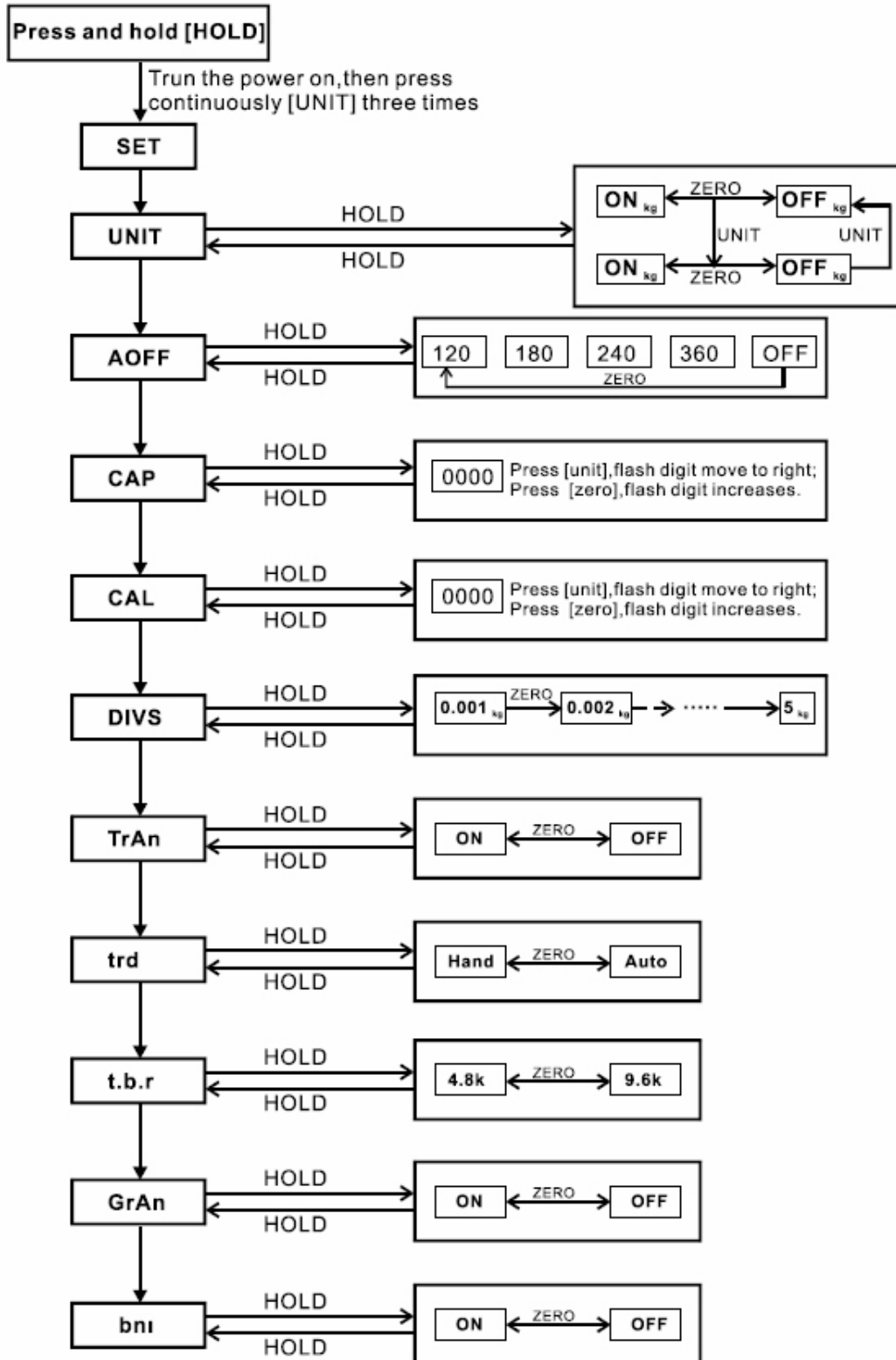

THE MEANING OF FUNCTION SETTING

1. **AOFF** Time for auto off (120s / 180s / 240s / 360s / off)
2. **Unit** Weight units: kg / lb
3. **CAP** Capacity (1 ~ 9999 kg)
4. **divS** Division (0,001 ~ 5 kg)
5. **CAL** Calibration weight (1 ~ 9999 kg)
6. **trAn** RS232 Transfer
7. **t.b.r.** RS232 Transfer band rate
8. **Grav.** Gravity
9. **trd.** Transfer mode
10. **BMI** WEIGHT/H2 (ON/OFF)

TABEL 2 – CALIBRATION WEIGHT

1. Press and hold **[ZERO]** to turn the power on, and then press continuously **[UNIT/WEIGHT]** three times, the display will show the “CALukg”.(press **[UNIT/WEIGHT]** key to selected the calibration unit)
2. Press **[ZERO]** key, when the display will show AD value, press **[ZERO]** key, the display will show “SAVE” and then show calibration weight.
3. Press **[ZERO]** key again, the display will show “SAVE” and then return to AD value. Now calibration weight is complete.

BMI FUNCTION SETTING

1. Body on the pan, it should your weght: 80kg
2. When the display stable, press HOLD to keep the display 80kg
3. Press and hold the HOLD key, until it display HLT 100, it means to input your height in cm
4. Press HOLD and UNIT keys until the display 180, it means 180cm
5. Press TARE, it display 80kg and 25%.

RS232 TRANSMIT FUNCTION

1. When the function **trAn** set **ON**, the RS232 is activated
2. Baud rate is selected 4800 or 9600 when the function **t.b.r** set 4800 or 9600.
3. RS232 Transmission Agreement:
 - Mode: Simplex Asynchronous Serial
 - Baud rate: 4800 or 9600
 - Data Bit: 8
 - Parity Bit: NONE
 - Stop Bit: 1
 - Data Format: ASCII
4. Transmission Information Format: 16 Byte, blank=20H
`<STX><Status><+/-><D><D><D><D><D><D><U><U><U><U><ETX>`
5. Transmission Information Format show:
 - STX: Start of Transmission=02H
 - Status: Status bit
 - Example: *=(2AH)=Stable weight, ~=(7EH)=Unstable Weight
 - +/-: +=(2BH)=Positive Weight, -=(2Dh)=Negat Weight
 - DDDDDDD: Value of Weight, 7 ASCII Code
 - UUUUU: 4 ASCII Code Weight Units: kg or LB
 - ETX: Stop of Transmission =03H

SETTING THE ACCELERATION TO GRAVITY MODE

1. Press [TARE] and [UNITS] first, then press [ON/OFF], while keeping [TARE] and [UNITS] pressed, the display will show "SEt", then press the [UNITS] several times until the display show "GrAv" press [TARE] the display show "on" press the [HOLD] the display show "OFF". When the display show "ON" means acceleration to gravity is activated. When the display show "OFF" means acceleration to gravity is inactivated.
2. When acceleration to gravity is activated press [ON/OFF] turn the power off, then press [ON/OFF] turn the power on, then press [UNITS] key 3 seconds enter to acceleration to gravity mode .1). when the display show "C9.0 00" (0 for flash digit) first setting the local gravity.2). press [TARE] key again, rightward flash digit, 3).press [HOLD] key, increase digit input the gravity value, press [UNITS] the display enter to another local acceleration to gravity mode.
3. When the display show "U9.0 00" (0 for flash digit) repeat the steps 1)-3) .press [UNITS] the display will return the normal weighing mode.

INTERFACE

1.Signal interface (microphone socket)

Pin 1 (red)-----	→ E+(positive source)
Pin 2 (blue)-----	→ S+(positive signal)
Pin 3 (black)-----	→ E-(negative source)
Pin 4 (white)-----	→ S-(negative signal)
Pin 5 (no)	
No sign -----	→ GND

2. Rechargeable battery socket: AC/DC 9V-----inner positive ,external negative

3. RS232 interface: DB9